

Electric Gas Valve and Manual Reset Relay



P/N: 60-9197XXX-000; 60-9101735-000

Effective: December 2014
B-87-023

FEATURES

- *For Use in:*
 - *Range Guard® Commercial Cooking Fire Suppression Systems*
 - *Industry Guard™ Industrial Fire Suppression Systems*
- *For Use with Badger Universal Control Head or A+ Control Box*
- *UL Listed and ULC Listed*
- *FM Approved for Industry Guard Systems*

DESCRIPTION

The Badger Electric Gas Valve (Figure 1) is used on systems protecting gas-fueled equipment (e.g., appliances). The Badger valve uses an electrically operated solenoid (120V, 60 Hz), which holds the valve in the open position. Upon system actuation or loss of electrical power, the valve closes, stopping the flow of gas to the equipment. All Electric Gas Valves must be installed horizontally with the solenoid up.

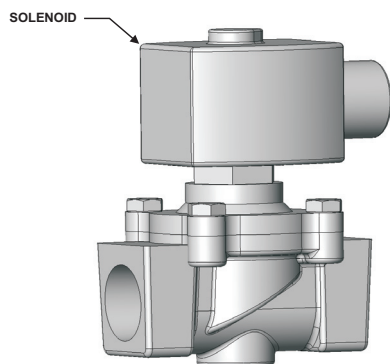

Figure 1. Electric Gas Valve

A Badger Manual Reset Relay, P/N 60-9101735-000, is required with all Badger Electric Gas Valves. The Manual Reset Relay (Figure 2) provides DPDT contacts rated for 10 amps at 120 Vac and prevents immediate reopening of the Electric Gas Valve.

The Electric Gas Valve and Manual Reset Relay must be specifically listed for use with the Badger Range Guard or Industry Guard suppression system.

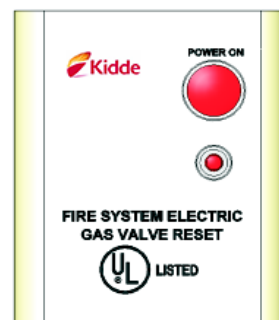

Figure 2. Manual Reset Relay, P/N 60-9101735-000

The Electric Gas Valve can be controlled via a Pressure Switch* installed in the discharge piping (Figure 3 and Table 1) or via a microswitch from the Universal Control Head or A+ Control Box* (Figure 4).

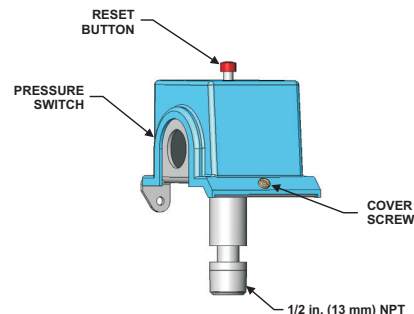

Figure 3. Pressure Switch, P/N 60-9197023-000

Table 1: Pressure Switch Electric Specifications

115/230 Vac	15 Amps
28 Vdc	5 Amps
75 Vdc	1 Amp
125 Vdc	1/2 Amp
250 Vdc	1/4 Amp
Yellow Wire	Common
Blue Wire	Normally Open
Black Wire	Normally Closed

MICROSWITCH CONTACTS SHOWN WITH
CONTROLLER IN SET POSITION

NOTE 1 - Control switch must be closed before the reset switch can be pressed.

NOTE 2 - To test, apply 120VAC to terminals 2 and 5. Then jumper 3 and 4. Push the reset and relay should operate. Remove jumper and relay will drop out.

All external wiring must conform to local electrical code.

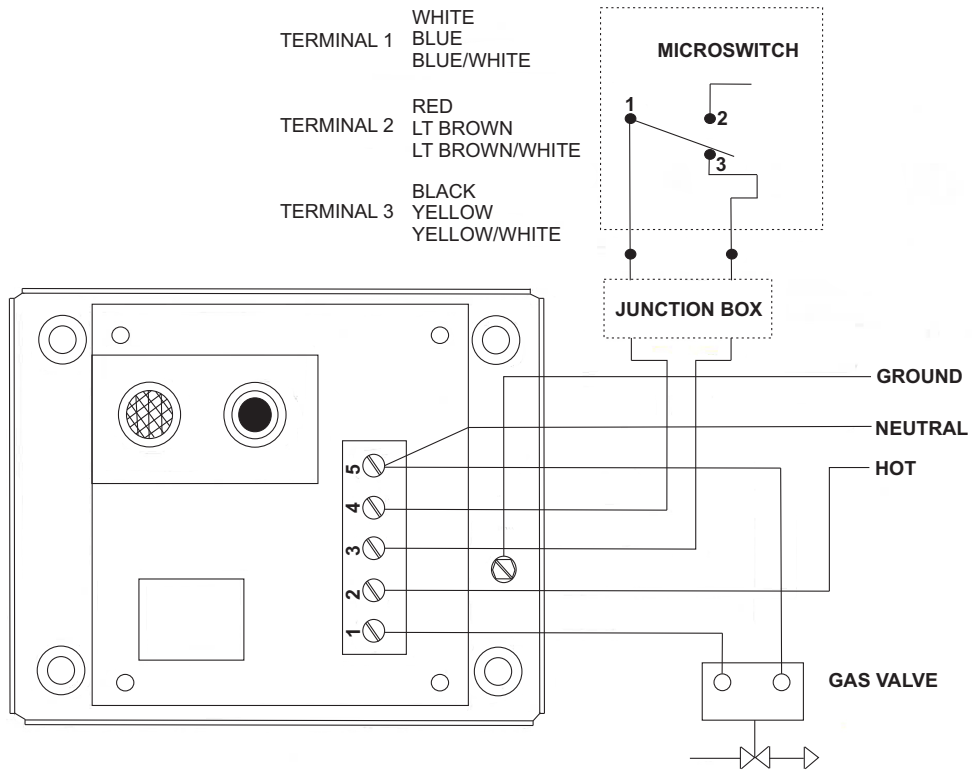

Reset Relay 10A, 120VAC
External Control Switch Closure Required

Figure 4. Manual Reset Relay Wiring for Microswitches

Ordering Information			
Description	Part Number	Description	Part Number
1/2-in. Electric Gas Valve	60-9197017-000	3-in. Electric Gas Valve	60-9197445-000
3/4-in. Electric Gas Valve	60-9197018-000	Manual Reset Relay	60-9101735-000
1-in. Electric Gas Valve	60-9197019-000	Microswitch, Quick Connect, Solid Leads (for UCH)	87-120039-001
1-1/4 in. Electric Gas Valve	60-9197020-000	Microswitch, Quick Connect, Striped Leads (for UCH)	87-120039-501
1-1/2-in. Electric Gas Valve	60-9197021-000	Microswitch, Quick Connect, SPDT (for A+)	60-9197227-000
2-in. Electric Gas Valve	60-9197022-000	Microswitch, Quick Connect, Dual SPDT (for A+)	60-9197228-000
2-1/2-in. Electric Gas Valve	60-9197444-000	Pressure Switch*	60-9197023-000

* Range Guard systems only.

Badger and Range Guard are registered trademarks of Kidde-Fenwal, Inc.
Range Guard is a registered trademark of Badger Fire Protection.
Industry Guard is a trademark of Badger Fire Protection.



This literature is provided for informational purposes only. BADGER FIRE PROTECTION assumes no responsibility for the product's suitability for a particular application. The product must be properly applied to work correctly. If you need more information on this product, or if you have a particular question, contact BADGER FIRE PROTECTION, Charlottesville, VA 22901. Ph: (434) 964-3200.

Badger Fire Protection
944 Glenwood Station Lane
Suite 303
Charlottesville, VA 22901
Ph: (434) 964-3200
Toll Free: (800) 446-3857
www.badgerfire.com

Kidde Canada, Inc.
340 Four Valley Drive
Vaughan, Ontario L4K 5Z1
Ph: (905) 695-6060
Toll Free: (800) 565-1976
www.kiddecana.com